

WHATCOM COUNTY
Planning & Development Services
Fire Marshal's Office
5280 Northwest Drive
Bellingham, WA 98226-9097
360-778-5900, TTY 800-833-6384
360-778-5901 Fax



J.E. "Sam" Ryan
Director/Fire Marshal

Mark Sniffen
Deputy Fire Marshal

Fire Marshal's Permit Assessment Checklist for Residential and Detached Accessory Buildings

Fire Flow Requirements

Note: Fire-flow calculation area shall be the total square footage of all areas within exterior walls, including only areas that are fully enclosed on all sides and which have a full ceiling height (6'-8" or greater). Area measured to the outside edge of enclosure walls. Breezeways connecting buildings will be included in the area measurement.

Grade per Exhibit A and WCDS, Chapter 5, Road Standards. Residential and residential accessory structures accessed by roads or driveways exceeding 12% grade require mitigation such as an automatic sprinkler system, per NFPA 13-D, throughout the applicable building(s); an approved fire flow system; equivalent mitigation approved at the discretion of the Fire Marshal in addition to standard access road requirements.

Required if
checked

- If a **remodel** is proposed, calculation of existing building area is required on application/plans for fire area calculation.
- Calculated fire-flow area is **greater than 4,000 square feet. Greater than 2500 square feet for detached accessory building.**
- One of the following options is required:
- A fire hydrant connected to a municipal or water association system within 600 feet (driving route) of the proposed building which produces a minimum 500 GPM at 20 psi for a minimum duration of one hour. ***Availability Notification for Public Fire Water form required.**
- An approved NFPA 13-D residential fire sprinkler system will be installed prior to occupancy. ***Separate Fire Marshal's Permit is required.**
- A fire flow system consisting of a tank or pond, approved fire pump, and a fire hydrant within 600 feet (driving route) of the proposed building. The system must produce 500 GPM at 20 psi for minimum duration of one hour. ***Separate Fire Marshal's Permit is required.**
- A NFPA 13-D automatic sprinkler system is required throughout all dwellings with a measured fire area exceeding 8,000 square feet. In addition, fire-flow for dwellings with a fire-flow calculation area exceeding 8,000 square feet (743.2 m²), shall not be less than that specified in Table B105.1, as amended by Whatcom County, except that the flow duration may be a minimum of one hour.

Select One

Driveway and/or Private Road Requirements

Note: All driveways must have an overhead clearance of 13' 6" for entire required width of the driveway.

- Private access bridges include all applicable information from the **Private Bridge Permit Review Checklist** and complete engineer's assessment submitted with application
- Requirements per the "Private Roadway or Driveway Matrix" are shown on an appropriately scaled site plan.
- Scaled site plan clearly shows **entire length of driveway from Whatcom County maintained road**, up to the proposed structure.
- Driveway is 150' or greater in length:
Fire apparatus turn-around feature required on scaled site plan.
Note: Must be no closer than 50' and no further than 150' from structures. (See example handout)
*Address post required to mark long driveways.
- Driveway is 600' or greater in length:
Fire apparatus turn-out feature(s) required on scaled site plan. Multiple turn-outs may be required, depending on length of driveway. (See example handout)
- Portions of the driveway or private road are 12% or greater in grade.
Residential fire sprinkler system, meeting NFPA 13D, will be installed due to steep driveway. (Separate Fire Marshal's Office permit is required)
- Security gate locations are shown on scaled site plan, if proposed. (Separate Fire Marshal's Office permit is required for all security gates and other emergency access restrictions)

Private Roadway or Driveway Matrix					
Road Users ⁽¹⁾	Incremental Grade, %	Minimum Surface Treatment	Width (ft)	Minimum curve Radii (ft)	
				Inside	Outside
1 – 2	<12	CSTC ⁽²⁾	12 (minimum)	25	40
	12 – 14	Paved ⁽³⁾			
	15 – 18	Heated, Grooved PCC ⁽⁴⁾			
3 – 6	<12	CSTC ⁽²⁾	18	25	43
	12 – 14	Paved ⁽³⁾			
	15 – 18	Heated, Grooved PCC ⁽⁴⁾			
7 +	<12	Paved ⁽³⁾	26	25	43
	12 – 14	Paved ⁽³⁾			
	15 – 18	Heated, Grooved PCC ⁽⁴⁾			

(1) Road Users represents the number of dwelling units/single households. Per the Public Works Dept., a single household is the approximate equivalent of 6 average daily trips (ADT).

(2) Crushed surfacing top course

(3) Either PCC or Hot Mix Asphalt

(4) Portland Cement Concrete

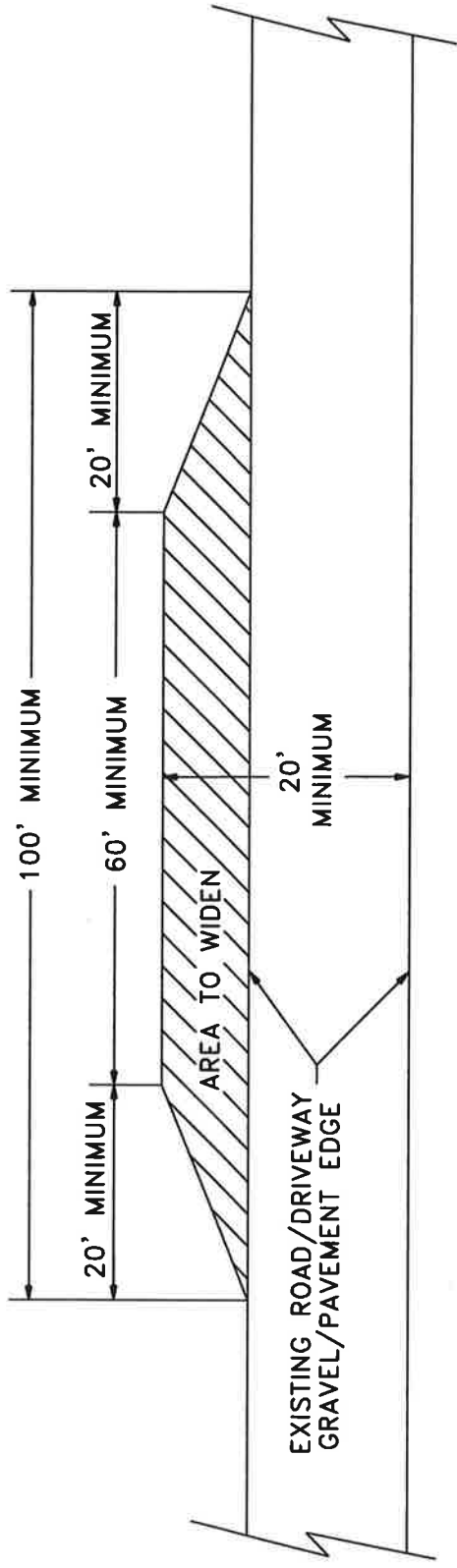

PLAN VIEW

- NOTES:
1. Widening may be done on either side of the roadway or driveway.
 2. Widened area to have the same standard section detail as roadway or driveway.

DRIVEWAY/ROADWAY LENGTH	NUMBER OF TURNOUTS
0 - 600 feet	No turnout
601 - 1200 feet	One at mid-point
Over 1200 feet	Every 600 feet

EXHIBIT B

PRIVATE ROAD OR DRIVEWAY
TURNOUT DETAIL

WHATCOM COUNTY FIRE MARSHALL

FULL CIRCLE DRIVEWAY TURNAROUND

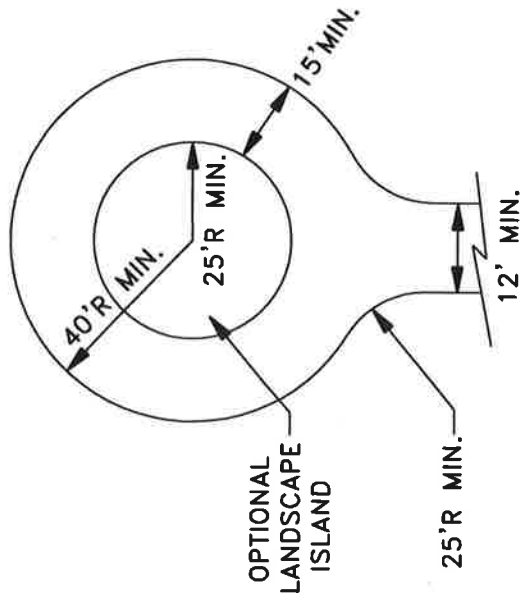

DRIVEWAY SECTION

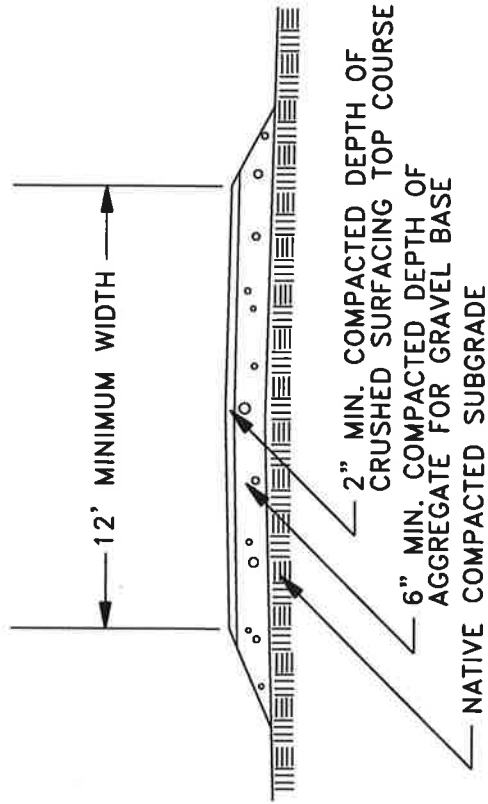

MINIMUM DRIVEWAY CURVE

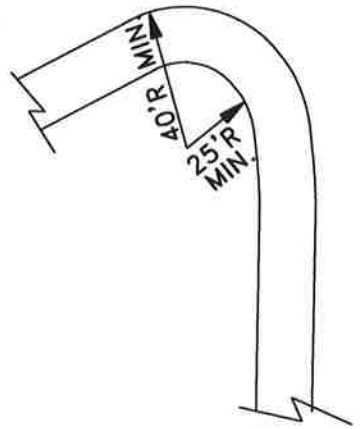

EXHIBIT C

PRIVATE DRIVEWAY DETAILS

WHATCOM COUNTY FIRE MARSHALL

Not to Scale

5/27/2013

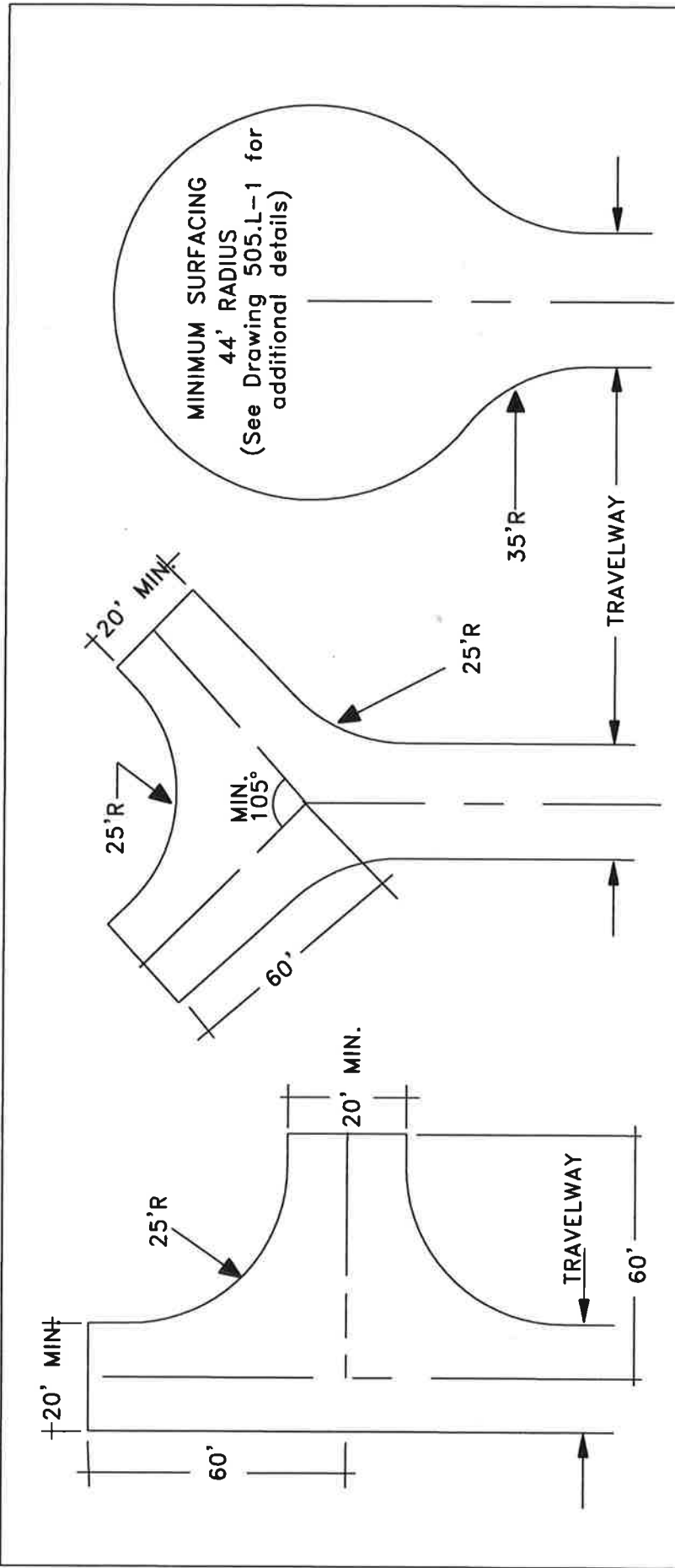

NOTES:

1. Turnarounds shall be within the County right of way and/or private easements.
2. Width of travelway is specified on Exhibit A, or the approved plans.
3. Turnaround construction shall be of approved subgrade, base, and top course.

NOTE: The length of the leg of a turnaround may be reduced from 60 feet to 45 feet for residential and residential accessory applications.

EXHIBIT D
PRIVATE ROAD AND NON-MAINTAINED COUNTY RIGHTS-OF-WAY TURNAROUND DETAILS
WHATCOM COUNTY FIRE MARSHALL

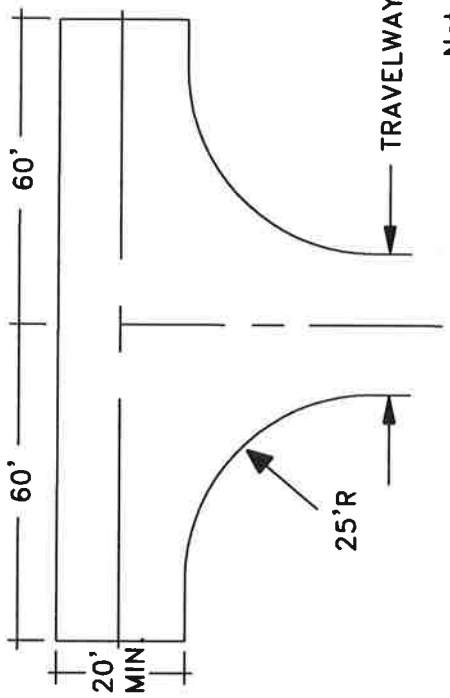

Not to Scale